

ROCKVILLE

ATV300

IP65 RATED MONO MICRO AMP for
UTVs, ATVs, and MOTORCYCLES

OWNER'S MANUAL

ATTENTION:
WATCH THIS VIDEO BEFORE FIRST USE!

Who reads manuals?

Scan the **QR code** or go to rockvillesupport.com/atv300 to access how-to video(s), the owner's manual, and other important information you may need to get the most out of your item.

If you prefer written instructions, please read ahead!

With Rockville you get many options.

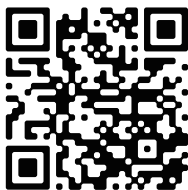

Missing items? If you ordered a bundle that includes more than one product and you are missing part of your bundle then it just means your order shipped from two different warehouses. You will receive the remaining items very soon. If you have any concerns or inquiries, feel free to call our customer support center at 1-646-758-0144, 24 hours a day/7 days a week.

Thank you for purchasing this Rockville ATV300 amplifier. Please read this owner's manual carefully for proper use of your ATV300. Should you need assistance, please call our technical help line at 1-646-758-0144, 24 hours a day/7 days a week.

IMPORTANT SAFETY INSTRUCTIONS



- To reduce risk of electric shock, never open the unit. There are no user serviceable parts, refer service to the Rockville service center.
- Please ensure that the unit is situated in a properly ventilated area.

Wiring

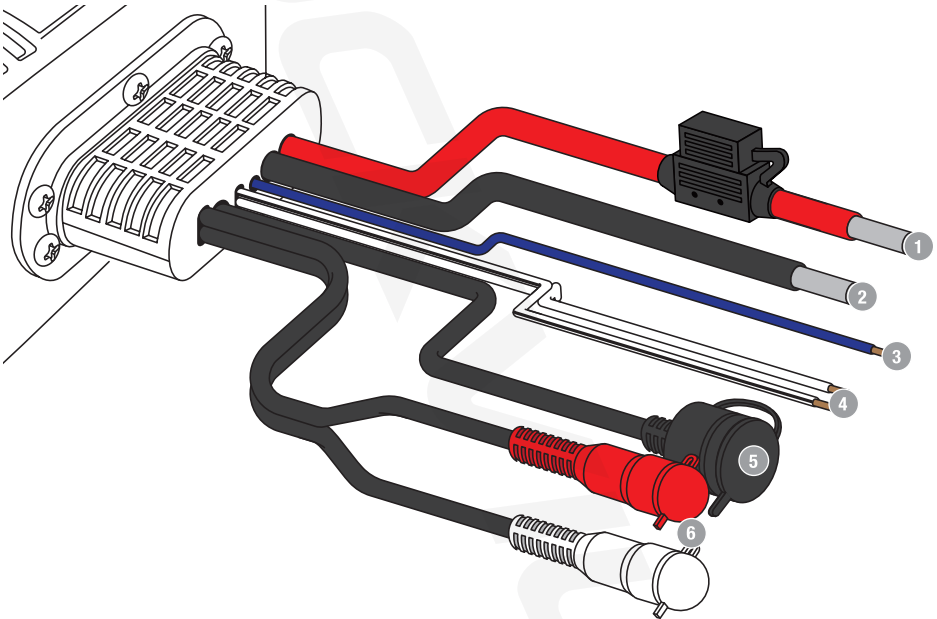

1. Power cable (+12V, red)
2. Ground cable (black)
3. Remote turn-on cable (blue)
4. Subwoofer output cables: negative (white w/black stripe) and positive (white).
5. Remote control port
6. Left (white) and Right (red) RCA inputs

Power Connections

1. Make sure to disconnect the **NEGATIVE (-)** terminal from your vehicle's battery.
2. Attach a 10-gauge or heavier wire to the black cable from the harness marked **GND**. The connection should be as close to the amp as possible). The wire should terminate in a ring connector. Connect the ring connector to a metal part of the vehicle's chassis, making sure that there is no paint or other insulator blocking a good ground connection. If needed, you can connect to the battery's negative terminal.
3. Attach a 10-gauge or heavier wire to the red cable from the harness marked **+12V** to the battery's **POSITIVE (+)** terminal. The power wire should terminate in a ring terminal connected directly to the **POSITIVE (+)** terminal.
4. Connect the blue remote wire to the head unit's remote output using 18-gauge or heavier wire. This connection is responsible for turning the amplifier on and off with the rest of the system. Should your head unit not have any turn-on leads, you can wire the remote terminal to an accessory lead, which turns the amplifier on with your vehicle's ignition.

! ATTENTION: Never connect the remote wire directly to the battery. If you do so the amp will receive constant power which will drain your vehicle's battery and possibly damage the amp.

Please note, it is a good practice to feel the power and ground wires near the amplifier after using the amp for a while. If the wires feel hot to the touch, you probably have a bad or loose connection. If after adjusting your connections the wires still feel hot, you should upgrade to the next heaviest gauge wire. As connections can work loose due to vehicle vibrations, we recommend periodically tightening all power and ground connections.

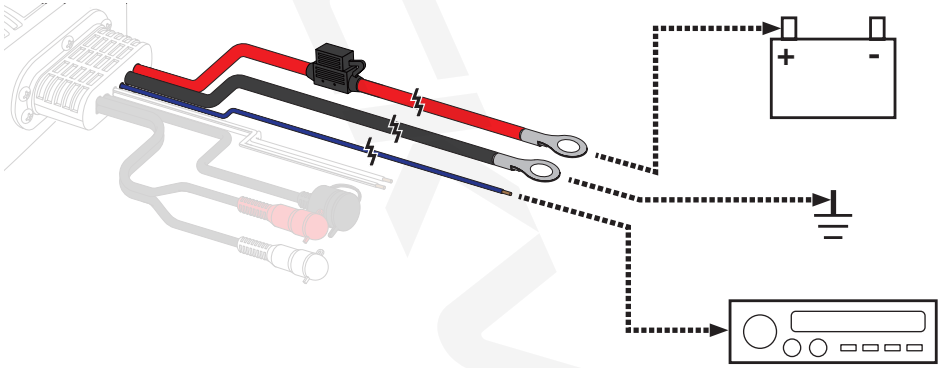

Input Configurations

Connect your head unit's subwoofer outputs to the amplifier's Left and Right RCA input jacks.

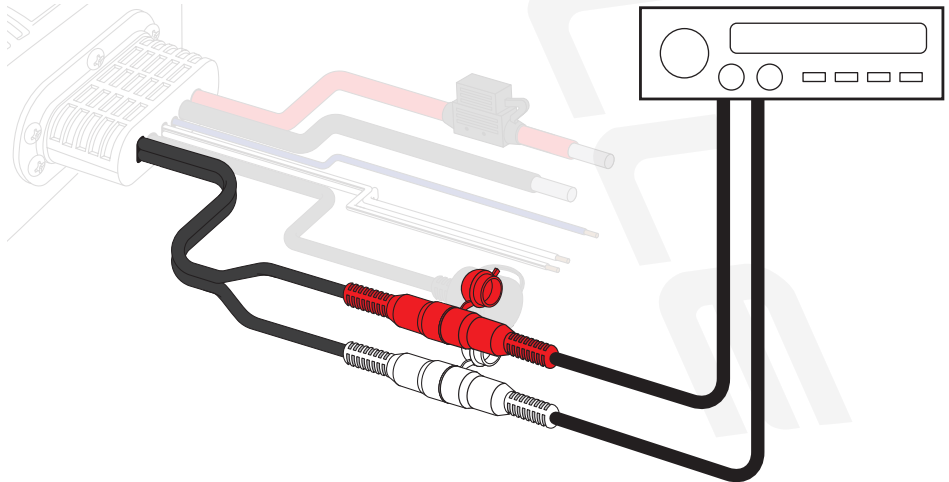

Input Configurations (continued)

High Level Input (used with factory head unit or if the head unit has no RCA outputs)

High level inputs, also referred to as speaker level inputs, allow you to connect to the factory speaker wires. These inputs are used when you want to connect an amplifier to your factory radio or an aftermarket radio that does not have low-level (RCA) inputs. They convert the high voltage running through the factory speaker wires to a voltage the amplifier can handle. These inputs will provide the end user with clean, well defined sound for optimal musical enjoyment.

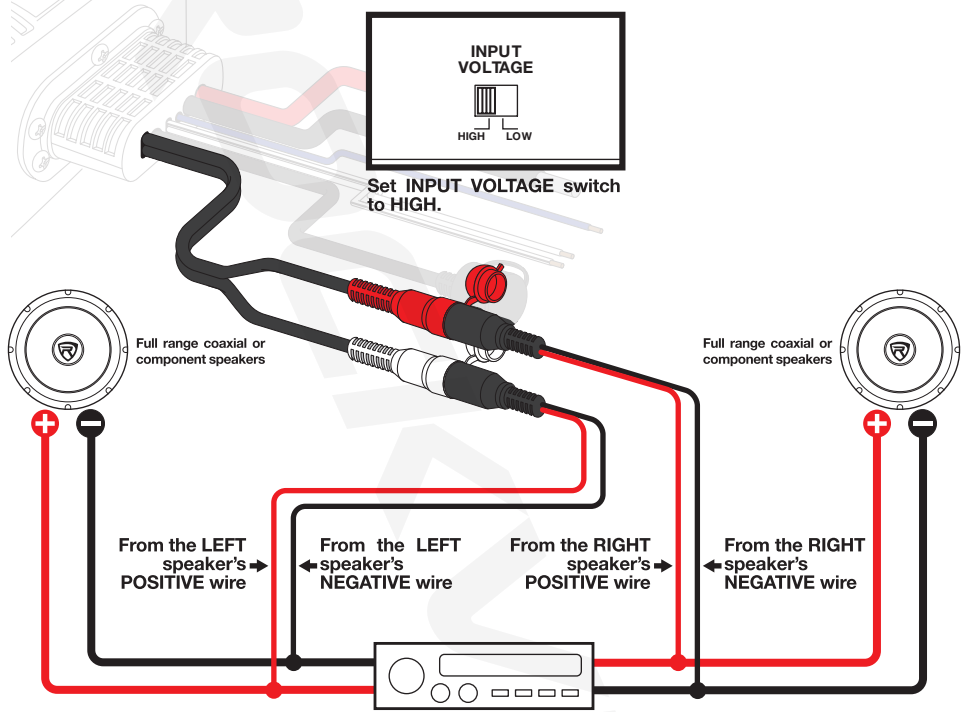

Output Configuration

These amps are 2 ohm stable monoblock amplifiers, **the final impedance should not fall below 2 ohms.**

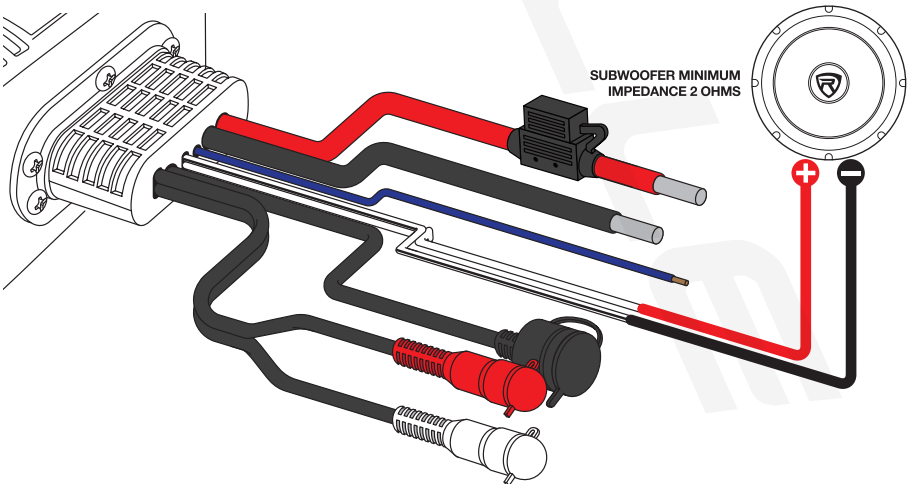

Adjusting the System

1. Once the system is operational, set all crossover points to the approximate settings. In the case of a basic subwoofer system, set the Low Pass Filter (LPF) crossover at 100Hz or so. Turn the controls using a small flathead screwdriver. Do not apply any pressure while turning as this might break the control unit.
2. Set the amplifier's Input Sensitivity using the control accessible on the side of the amplifier marked LEVEL (gain). Turn it counterclockwise to the MIN position. Adjust your head unit's volume gain to the maximum it can go before signal distorts or to the loudest gain, which is usually about 75% – 85% on most head units (you can also use an oscilloscope to see at what gain level your head unit distorts). When you begin to hear distortion, back down one notch. Now turn the LEVEL control on the amp clockwise until you hear distortion, then turn it counterclockwise by a notch or until the distortion is gone. The amp's input sensitivity is now set. It is helpful to have a second person to help you set the gain. When setting up a multi-amp system, set each amplifier's level controls separately. Start off with the bass amplifier, then adjust the highs amplifier's level control to match. Please note that the level control of any vessel's amplifier should not be mistaken for a volume control. It is a sophisticated device designed to match the output level of your source unit to the input level of the amplifier. Do not adjust the amplifier level to maximum unless your input level requires it. Your system can also be extremely sensitive to noise when the input level is set to maximum and does not match your input signal. These adjustments need to be made only once when first setting up the system.
3. Once you are satisfied with the level control settings, use any equalizer controls to adjust the system's tonal level for personal preference. Keep in mind that after equalizing you may have to go back and reset the amplifier's level controls. **If your unit has been professionally installed please do not change the gain settings set by the installer, he or she is the professional!**

Features

Input Voltage Switch

This switch allows you to set the voltage sensitivity to match the input source. For example, if you are using a head unit with pre outs, you set the switch on the amp to low (a). If you are using a factory radio, use the included adapters to wire the amp's RCA inputs to the factory speaker outputs. Then set the switch to high (b) so that all input goes to the RCA jacks.

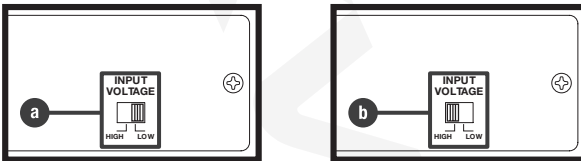

Bass Remote

The dash-mounted bass remote allows you to easily control the amplifier's bass level.

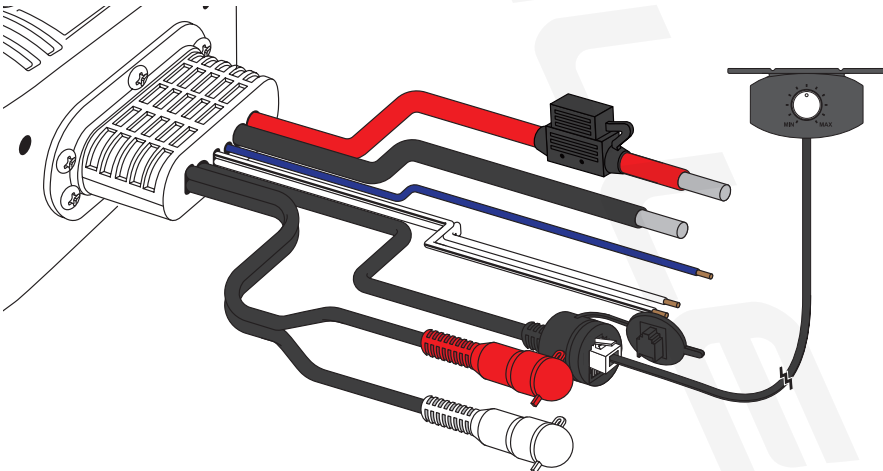

Features (continued)

Power/Protect LED

This model features one LED (located on the left side of the harness) that provides indication of the amplifier's status. The LED will light green when the amplifier is receiving proper power, ground, and remote voltages. In case the amplifier encounters a diagnostic condition as listed below, the LED will light red indicating a diagnostic condition. When a diagnostic condition is sensed, the amplifier will then turn into self-preservation mode and if the cause of the diagnostic condition is not corrected will eventually shut down.

Thermal Protection: When the amplifier reaches an unsafe operating temperature of 80 degrees Celsius, the amplifier will turn off. Once the amplifier cools down to a safe temperature, it will automatically turn on again. If you live in a hot climate, we suggest installing additional cooling fans to exhaust the hot air which can build up in the trunk. This will help keep the ambient temperature in the trunk as low as possible so that your amps work flawlessly and without any musical interruption.

Speaker Short Circuit Protection: Should your Subwoofers short circuit due to voice coil burn out, or should the amplifier sense an impedance too low to handle, the protection LED will light red, indicating a diagnostic condition. Turn off your system, disconnect one subwoofer at a time, and try to determine which subwoofer might be faulty. Correct the condition and restart the amplifier. You must reset the amplifier by turning it OFF and then ON again by the Remote power connection after correcting a diagnostic condition. (Turn your radio off and then on again.)

Input Overload Protection: This circuit will either shut down the amplifier completely or make the amplifier spurt on and off indicating that it is in a diagnostic condition. Turn the system off and reduce the gain on the amplifier or volume from your head unit. This should result in a corrected condition.

DC Offset Protection: Should any DC voltage try to enter the amplifier via the subwoofer terminals it will cause the amplifier to shut down and not operate until this condition is remedied. This circuit will also protect damaging high DC voltages from reaching your subwoofers should your amplifier ever malfunction.

PLEASE NOTE: You must reset the amplifier by turning it OFF and then ON again after correcting a diagnostic condition (turn your radio off and then on again). If the amplifier stays in protection after a reset, it is most likely faulty.

Additional Features

- IP65 waterproof rating
- All inputs and wire wiring is sealed and covered
- Conformal coated circuit board
- Anti rust materials
- Micro Size amplifier can easily fit in tight spaces
- Digital Class D Audio Topology
- High Input (Speaker level Input)
- Waterproof sheath RCA Input
- High-Speed MOSFET Power supply
- Status Mode LED Indicator

Specifications

- Dyno Certified RMS Power Ratings (Certified Dyno Test / Less than 1 % THD)
(Use these ratings when comparing with top brands such as Kicker, Rockford Fosgate, etc)
 - 2 Ohms: 300 Watts
 - 4 Ohms: 160 Watts
- Peak (Use these ratings when comparing with the top budget brands such as Boss, Power Acoustik, etc):
 - Peak 2 Ohms: 1200 Watts
- Low Pass Filter: 32Hz – 320Hz
- Subsonic High Pass Filter: 32Hz – 60Hz
- Frequency Response: 20Hz – 22kHz
- Signal to Noise Ratio (1 Watt into 4 Ohms): $\geq 80\text{dB}$
- Low Input Sensitivity: 0.2V – 6V
- Distortion(THD): $\leq 0.5\%$
- Speaker/High level Input Sensitivity: 0.5V – 15.5V
- Fuse Rating: 35A
- Dimensions (Inches): 8.66" L x 3.74" W x 1.73" H

Troubleshooting

PROBLEM	SOLUTION
Unit will not power up	<ol style="list-style-type: none"> 1. Check your ground connection. 2. Check that the Remote Input Turn-On has at least 5V DC. 3. Check that there is battery power going to the +12V terminal. 4. Check all fuses, replace if necessary. 5. Make sure the protection LED is not on. If it is, shut off the amplifier briefly and then turn it back on.
Protection LED comes on when amplifier is powered up	<ol style="list-style-type: none"> 1. Turn down the volume control on the head unit to prevent overdriving. 2. Check that there is good air flow around the amp. 3. Check the wiring of the power supply and subwoofers Check the POWER/PROTECT LED section on page 6 for more information.
No Output	<ol style="list-style-type: none"> 1. Check the fuse. 2. Check that the unit is properly grounded. 3. Check that the Remote Input Turn-On has at least 5V DC. 4. Check that all inputs to the harness are properly connected. 5. Check the input source's power and output settings. 6. Check the headunit's output setting and enable sub output. 7. Check the amp to make sure the input level switch is on HIGH (if using factory speakers) or LOW (if using RCA inputs). 8. Check the amp's gain setting.
Low Output	<ol style="list-style-type: none"> 1. Check that all inputs to the harness are properly connected. 2. Check the input source's power settings. 3. Check the input voltage switch. 4. Check LPF settings 5. Check Subsonic HPF settings
High Hiss in the sound	<ol style="list-style-type: none"> 1. Check that all inputs to the harness are properly connected. 2. It is best to set the amplifier's gain control as low as possible. The best subjective signal-to-noise ratio is achieved in this manner. Try to set the head unit's volume level as high as possible without distortion.
Squealing noise is present	Check for improperly grounded RCA interconnects. Keep the audio and power cables separated.
Distorted sound	Check that the Input Gain control is set to match the signal level of the head unit and bring it back down. Check bass boost; make sure it is not set too high.
Engine noise: Static type	<ol style="list-style-type: none"> 1. Route your input cables away from the vehicle's wiring. 2. Use high quality RCA cables.
Engine noise: Alternator whine	<ol style="list-style-type: none"> 1. Check that the RCA grounds are not shorted to the vehicle chassis. 2. Check that the head unit is properly grounded.

FEDERAL COMMUNICATIONS COMMISSION COMPLIANCE INFORMATION

Responsible party name: Rockville

Address: 600 Bayview Ave.

Entrance A

Inwood, NY 11096

Hereby declares that the product(s) ATV300 complies with FCC rules as mentioned in the following paragraph: This device complies with Part 15 of the FCC rules. Operation is subject to the following two conditions: (1) this device may not cause harmful interference, and (2) this device must accept any interference received, including interference that may cause undesired operation.

Note: This equipment has been tested and found to comply with the limits for a Class B digital device, pursuant to Part 15 of the FCC rules. These limits are designed to provide reasonable protection against harmful interference in a residential installation. This equipment generates, uses, and can radiate radio frequency energy and, if not installed and used in accordance with the instructions, may cause harmful interference to radio communications. However, there is no guarantee that interference will not occur in a particular installation. If this equipment does cause harmful interference to radio or television reception, which can be determined by turning the equipment off and on, the user is encouraged to try to correct the interference by one or more of the following measures:

- Reorient or relocate the receiving antenna.
- Increase the separation between the equipment and receiver.
- Connect the equipment to an outlet on a circuit different from that to which the receiver is connected.
- Consult the dealer or an experienced radio/TV technician for help.

RockvilleAudio.com

© 2024 ROCKVILLE // Features and specifications are subject to change and/or improvement without notice.