

ROCKVILLE

RPA60BT V2

PROFESSIONAL MIXING KARAOKE AMPLIFIER
w/FM DIGITAL TUNER, BLUETOOTH, and USB

OWNER'S MANUAL

ATTENTION: VISIT THE ROCKVILLE SUPPORT SITE FIRST!

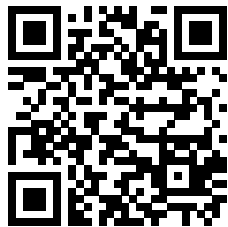

Who reads manuals?

Scan the **QR code** or go to rockvillesupport.com/rpa60bt-v2 to access how-to video(s), the owner's manual, and other important information you may need to get the most out of your item.

If you prefer written instructions, please read ahead!

With Rockville you get many options.

Missing items? If you ordered a bundle that includes more than one product and you are missing part of your bundle then it just means your order shipped from two different warehouses. You will receive the remaining items very soon. If you have any concerns or inquiries, feel free to call our customer support center at 1-646-758-0144, 24 hours a day/7 days a week.

Thank you for purchasing this Rockville RPA60BT V2 Professional Mixing Karaoke Amplifier. Please read this owner's manual carefully for proper use of your Rockville RPA60BT. Should you need assistance, please call our technical help line at 1-646-758-0144, 24 hours a day/7 days a week.

IMPORTANT SAFETY INSTRUCTIONS



- To reduce risk of electric shock, never open the unit. There are no user serviceable parts, for service to an authorized Rockville service center.
- Do not expose this unit to any kind of moisture.
- Do not place this unit near heat sources or expose to direct sunlight.
- Do not place anything on top of unit. Doing so will block vents and cause the unit to overheat.
- Please ensure that the unit is situated in a properly ventilated area.

Functions

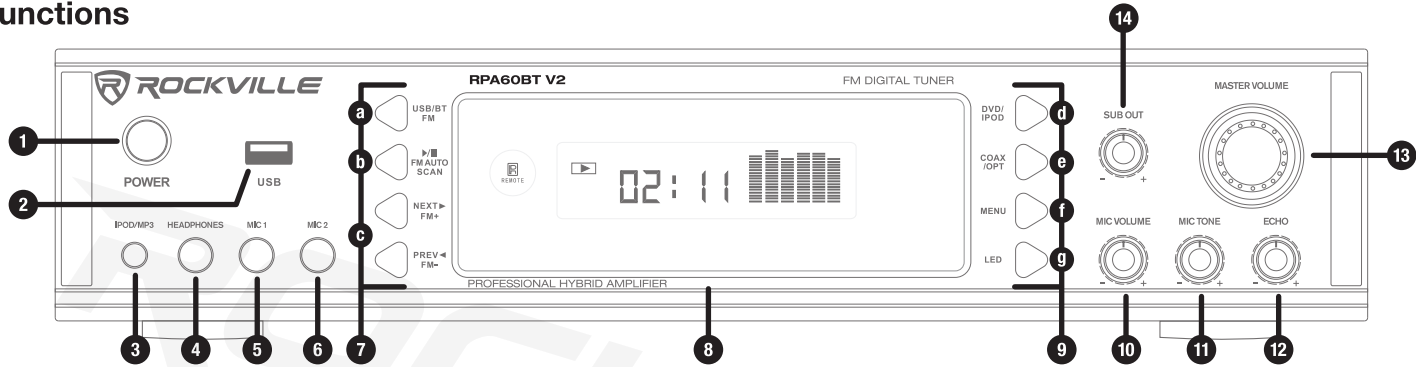

1. Power Button
2. USB input
3. 3.5mm TRS iPod/MP3 input
4. 1/4" TRS headphone output
5. 1/4" TS Microphone 1 input
6. 1/4" TS Microphone 2 input
7. Functions 1:
 - a. USB/BT/FM: Toggles between USB, Bluetooth, and FM input.
 - b. Play/Pause, FM Auto Scan: In USB mode, use the button to play or pause the current track. In Tuner mode, use to scan between stations. Press and hold for several seconds to store a station. This unit can store up to 50 stations.
 - c. Previous/Next buttons: In USB mode, use these buttons to go to the previous or next track. In Tuner mode, use these buttons to go to the previous or next station.
8. Vacuum Fluorescent Display
9. Functions 2:
 - d. DVD/IPOD: Toggles between DVD and iPod input.
 - e. COAX/OPT: Toggles between Coaxial and Optical input.
 - f. Menu: Press this button repeatedly to toggle between options in the settings menu (Bass, Treble, Balance). Use the Master Volume knob to make adjustments to the desired setting.
 - g. LED: Dims LED illumination.
10. Microphone Volume
11. Microphone Tone
12. Microphone Echo
13. Master Volume: Controls overall output volume. If you are in the settings menu mode, this knob can be used to adjust Bass, Treble, and Balance. In FM mode, it can be used to move navigate preset stations.
14. Subwoofer Output Volume control.

Functions (continued)

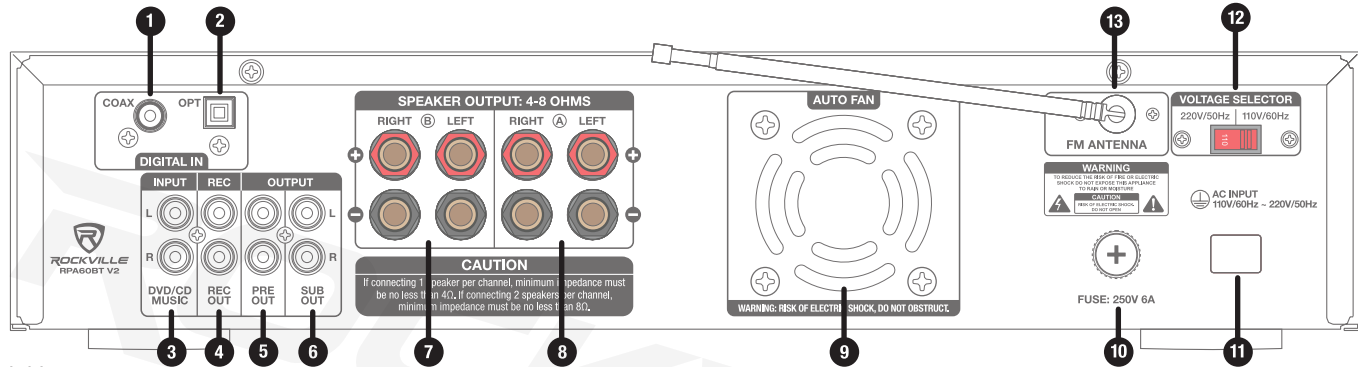

1. Coaxial input
2. Optical input
3. RCA signal in
4. Audio Record signal output (non-mixed music output only)
5. Pre Amp Audio signal output (mixed output including wireless microphones)
6. Subwoofer output
7. Speaker output A
8. Speaker output B
9. Cooling fan
10. User serviceable fuse
11. AC power cord
12. Voltage selector switch (110/220V)
13. Telescoping Fixed FM Antenna

IMPORTANT

WHEN POWERING 4 SPEAKERS MINIMUM IMPEDANCE PER SPEAKER CAN BE NO LOWER THAN 8 OHMS. USING 4 SPEAKERS AT 4 OHMS WILL EVENTUALLY CAUSE UNIT FAILURE.

NOT OPTIMIZED FOR DUAL BANANA PLUG SPACING. USE SINGLE PLUGS OR CONNECT RAW WIRE TO BINDING POST.

Setup

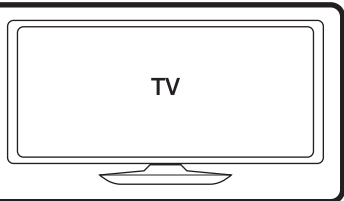
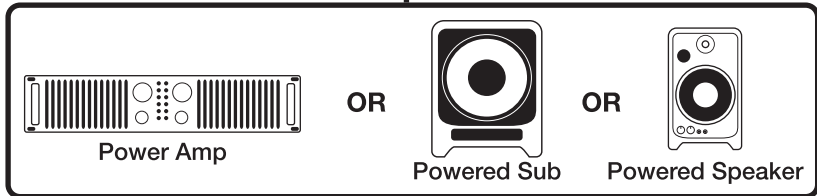
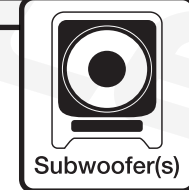
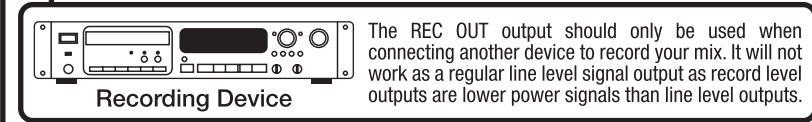
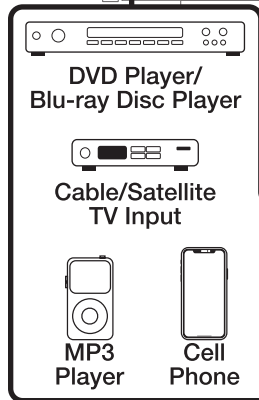
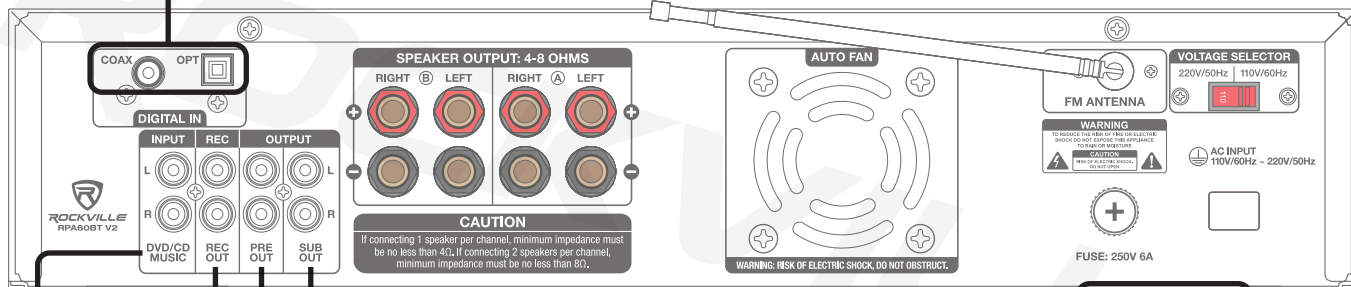
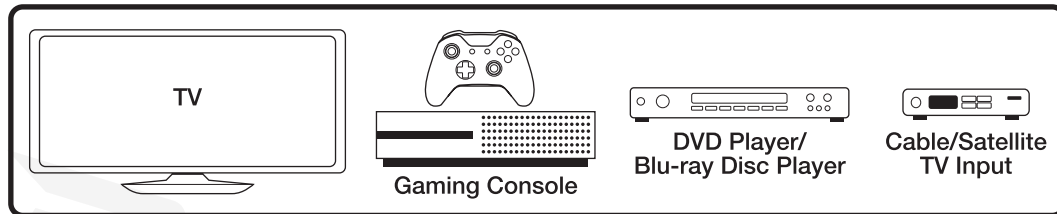

Setup (continued)

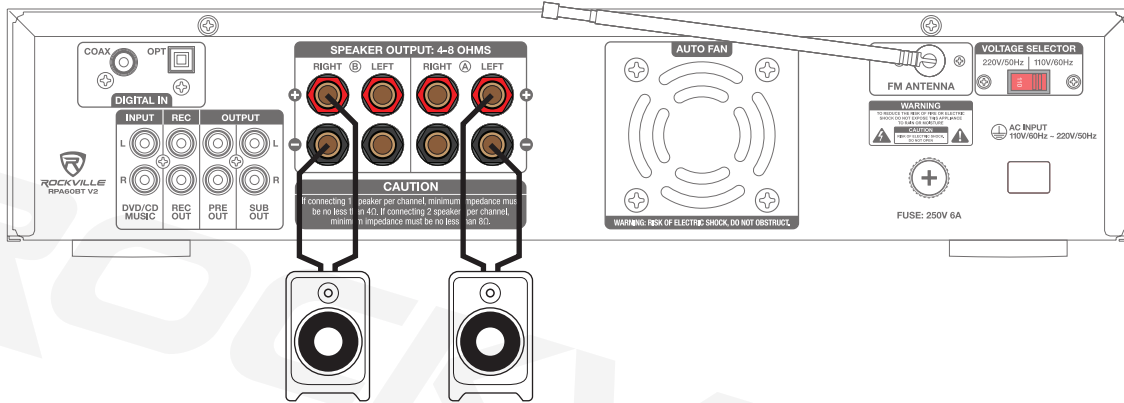

Two 4Ω or two 8Ω speakers

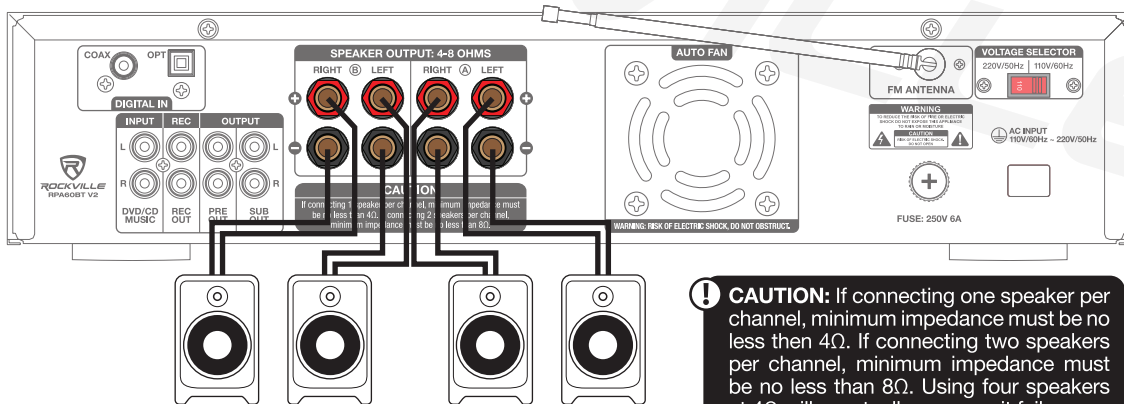

Four 8Ω speakers

! CAUTION: If connecting one speaker per channel, minimum impedance must be no less than 4Ω. If connecting two speakers per channel, minimum impedance must be no less than 8Ω. Using four speakers at 4Ω will eventually cause unit failure.

Remote Control

1. Input button: Switch between input sources.
2. Power button
3. Numeric key pad: In USB mode use to manually select tracks. In radio mode use to manually select stored stations.
4. Tuning buttons: Use to fine tune FM stations.
5. Scan button: Press to automatically search and store available FM station.
6. Mute
7. Left and right audio balance.
8. Treble adjustment button
9. Play/Pause button: Play and pause music from USB input.
10. USB/BT: Press to directly select USB or Bluetooth mode.
11. Repeat button: Repeats current track from USB input
12. DSP: Press to cycle through the preset EQs: Live, Hall, Matrix, Disco, Theater, Church, Pops, Classic, and Off
13. Display: activates spectrum display mode.
14. Tuner: press to directly select FM radio mode.
15. Memory button: Allows user to save selected stations.
16. Stereo/Mono button: Toggles between Stereo and Mono modes.
17. Master Volume +/- buttons: Press to increase or decrease volume level.
18. Bass adjustment button
19. Previous/Next buttons: In USB mode only, move back or forward through tracks.
20. Reset: Reset unit to factory settings.

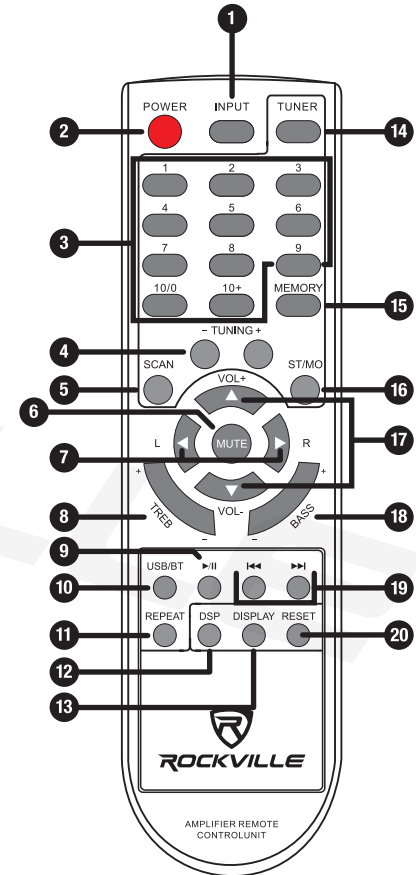

Bluetooth Function

1. Press the INPUT button located on the front panel select Bluetooth mode. You will hear a tone and see the word “blue” on the screen.
2. Turn on the Bluetooth feature on your device and ensure that it is in “discoverable” mode. Search for “RPA60BT V2” on your list of available devices and select it. If pairing is successful you will hear a tone. You can control all features (play/pause, next, previous, volume) via the unit or the included remote control.
3. After initial pairing, the RPA60BT V2 will pair with your device automatically.
4. To un-pair simply disconnect the RPA60BT V2 via your device. If un-pairing is successful, you will hear a tone.

USB Function

1. Connect a USB drive to the USB port on the front panel. The unit will automatically begin playing music.
2. You can control all features (play/pause, next/previous, volume) via the unit or the included remote control.

Please note:

- Accepted file formats are MP3 and WAV. Files must be properly formatted, simply changing the file extension to one of the specified formats will not work.
- The maximum capacity of the drive must not exceed 64Gb.
- The USB drive will charge an iPod, but does not offer playback functionality.

Fuse replacement Diagram

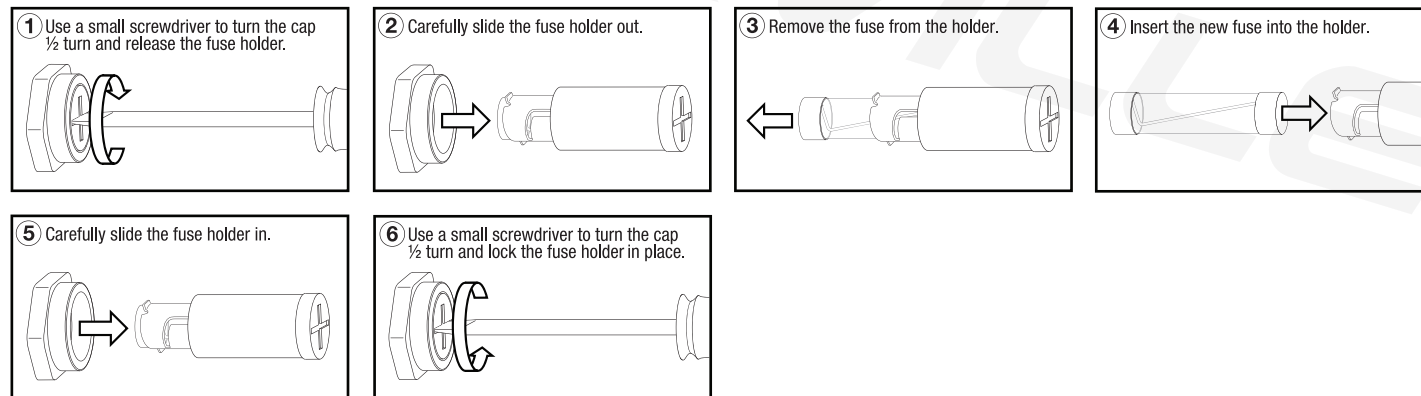

Features/Specifications

- RMS Power @ 4 Ohms: 125w x 2
- Peak Power @ 4 Ohms: 500w x 2
- RMS Power @ 8 Ohms: 100w x 2
- Peak Power @ 8 Ohms: 400w x 2
- THD: > 0.1%
- Input Sensitivity: 400mv/33k Ohm
- Frequency Response: 20Hz – 20kHz
- Signal to Noise Ratio: 80 dB
- Tone Characteristic: 100Hz – 10kHz \pm 12dB
- 110v/220v Switchable
- Front Inputs: 3.5mm aux input, (2) 1/4" Mic Inputs, USB Input
- Front Output: 1/4" Headphone Jack
- Rear Inputs: RCA, Optical, Coaxial
- Rear Outputs:
 - Preamp output for an external additional amplifier or powered speaker
 - Sub preamp output to connect a powered subwoofer or an amplifier
 - Record output to mixer or a recording device
- Bluetooth Capable
- Rear Speaker Terminals: Banana plug/binding post outputs
- Built-in Pre-Amplifier
- Bass, treble, and balance control knobs
- Multicolor VFD Display
- FM Radio Tuner with Presets & Auto-Scan
- Preset EQ: Rock, Pop, Classical, Jazz
- Remote control for quick access to all functions
- Vacuum Fluorescent Digital Output Display Meters
- Separate gain controls for master volume & subwoofer
- Digital Karaoke System
- 2 front microphone inputs with volume, tone and echo controls
- Built-in Mic Mixer with Echo Control
- USB input for music files from USB thumb drive
- 3.5mm input for iPod/MP3 player
- Spectrum analyzer equalizer display
- Turbo cooling twin fan system
- Dimensions with rack ears (W x D x H): 19" x 12.25" x 3.5"
- Dimensions without rack ears (W x D x H): 17" x 12.25" x 3.5"

Troubleshooting

| PROBLEM | SOLUTION |
|---------------------------------|---|
| No power | <ol style="list-style-type: none">1. Make sure the unit is plugged in and the power button is in the ON position.2. Check that the power cable is plugged in tightly to the unit.3. Check and replace the fuse if necessary. See fuse replacement diagram on page 8.4. If people or equipment tend to step on and roll over or stretch your power cable it can get damaged. Always try a second cable to test for shorts in original cable. Dispose of original damaged power cables immediately. |
| No sound | <ol style="list-style-type: none">1. Check that all appropriate cables are plugged in correctly.2. Check the Volume settings of the unit as well as any external input devices.3. Be sure your microphones are on, that you are using the proper type of cable, that they are properly connected, and that they are dynamic microphones.4. Check all output connections. |
| Bluetooth pairing fails | <ol style="list-style-type: none">1. Check to see that both devices are turned on and that your Bluetooth device is discoverable.2. Turn both devices off and then on again.3. Make sure you've selected the proper source.4. Make sure that the Bluetooth device is within 5 feet of the unit.5. Move both devices away from other Bluetooth devices, microwaves, wireless routers, and other electronics.6. Make sure that the unit is not paired to a previously paired device. |
| Mic feedback | Point the mics away from the speaker. Make sure the mics are in back of the speaker, not in front of it. |
| No mic sound/ poor mic sound | <ol style="list-style-type: none">1. Make sure the mics are turned on.2. Make sure you are using the appropriate cables.3. Check the mic volume control. |
| Buzzing sound | Be sure you are using the correct type of cable. Check the requirements of the connected gear for appropriate cable types. |
| No USB playback | <ol style="list-style-type: none">1. Make sure you've selected the proper source.2. Make sure that the USB drive and the audio files are properly formatted (MP3 or WAV).3. Make sure the drive capacity does not exceed 64Gb.3. Make sure that USB drive is properly plugged in.4. Check USB drive for damage. |

FEDERAL COMMUNICATIONS COMMISSION COMPLIANCE INFORMATION

Responsible party name: Rockville

Address: 600 Bayview Ave.
Entrance A
Inwood, NY 11096

Hereby declares that the product(s) RPA60BT V2 Professional Mixing Karaoke Amplifier with AM/FM Digital Tuner complies with FCC rules as mentioned in the following paragraph:

This device complies with Part 15 of the FCC rules. Operation is subject to the following two conditions: (1) this device may not cause harmful interference, and (2) this device must accept any interference received, including interference that may cause undesired operation.

Note: This equipment has been tested and found to comply with the limits for a Class B digital device, pursuant to Part 15 of the FCC rules. These limits are designed to provide reasonable protection against harmful interference in a residential installation. This equipment generates, uses and can radiate radio frequency energy and, if not installed and used in accordance with the instructions, may cause harmful interference to radio communications. However, there is no guarantee that interference will not occur in a particular installation. If this equipment does cause harmful interference to radio or television reception, which can be determined by turning the equipment off and on, the user is encouraged to try to correct the interference by one or more of the following measures:

- Reorient or relocate the receiving antenna.
- Increase the separation between the equipment and receiver.
- Connect the equipment to an outlet on a circuit different from that to which the receiver is connected.
- Consult the dealer or an experienced radio/TV technician for help.

ROCKVILLE

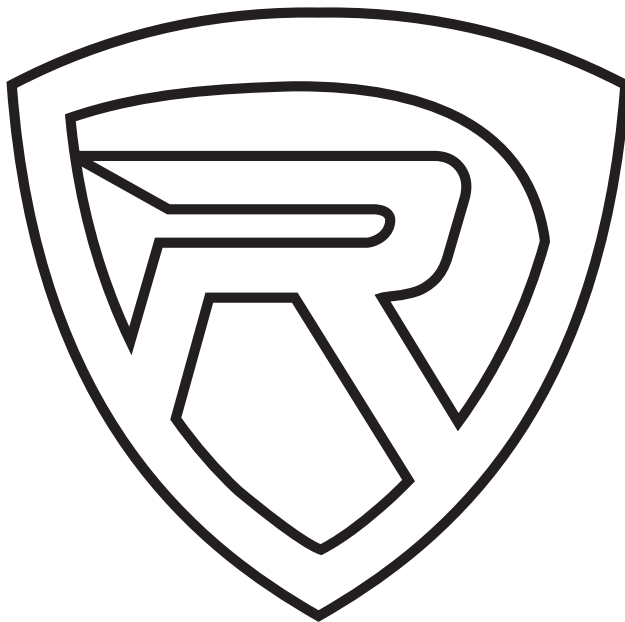

RockvilleAudio.com

© 2024 ROCKVILLE // Features and specifications are subject to change and/or improvement without notice.